

# TR 50.4

## Food Waste Disposer



### Product description

- Standard sound reduction technology 標準降噪技術
- Anti-corrosion protection; 防腐蝕保護
- Large capacity crushing chamber (980 ml) 大容量研磨室
- Drain accessories included 包括排水配件
- Pneumatic button (Ø 35 mm.) 氣壓掣開關
- Automatic change rotation direction 自動逆向磨碎系統
- Easy to install and use 容易安裝和使用
- Hygienic, functional and environmental protection 衛生, 多功能和環保
- Country of origin: USA 美國製造



### Electric Connection – Technical Features

Power Supply (V/Hz) 電壓	220-240/50 Hz
Power 功率	380W
Current 電流	3A
Motor 馬力 (匹數)	0.55 HP

### Installation Requirement

- Connect the disposer to 3 ½ inches water drainage of sink 接駁到3.5吋鋅盆去水位
- Connect the power (requires a 13A outlet) 接駁到13A電源插座
- Drill a hole in countertop/ Install with a box inside kitchen cabinet 安裝氣壓開關掣, 需在枱面開孔或安裝在廚櫃內

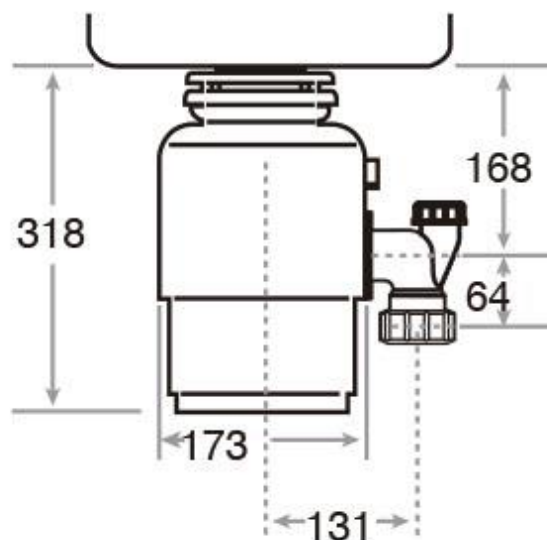

Application Dimension